

HSCD SERIES CARBON DIOXIDE SENSORS

Honeywell HSCD series carbon dioxide (CO₂) sensors include two types: indoor installation and duct installation. They are mainly used for detecting carbon dioxide concentration in air of indoor and duct.

Carbon Dioxide Duct Sensors are designed for the continuous monitoring of exhaust of carbon dioxide in non-hazardous areas. This series uses a wide spectrum, long life electrochemical sensor to measure the amount of carbon dioxide in the environment. The concentration of CO₂ is a strong indication of overall indoor air quality.



The HSCD Series Carbon Dioxide Sensors

FEATURES AND HIGHLIGHTS

- Use high-precision single/dual-wavelength NDIR sensors
- Optional display function, LCD digital display shows clearly.
- CO₂ sensing component module can be replaced on site.
- Multiple software and hardware protection design ensures high stability.
- CO₂ sensors can be manually calibrated on site.
- The air duct type adopts a screw-free clamshell snap-on design, making wiring and commissioning easy.
- Integrated RS485 matching resistor to facilitate on-site commissioning (Modbus models only).
- RS485 isolation design can isolate high voltage and enhance immunity to ground loops and common-mode signal interference (Modbus models only).



ORDER INFORMATION

ORDERING INFORMATION OF HSCD SENSOR

SKU	INSTALLATION	SENSING COMPONENT	OUTPUT SIGNAL OR PROTOCOL	DISPLAY
HSCD-D1U	Duct	Single wavelength NDIR	0-10V/2-10V//4-20mA	NO
HSCD-D1UL	Duct	Single wavelength NDIR	0-10V/2-10V//4-20mA	YES
HSCD-D2U	Duct	Dual wavelength NDIR	0-10V/2-10V//4-20mA	NO
HSCD-D2UL	Duct	Dual wavelength NDIR	0-10V/2-10V//4-20mA	YES
HSCD-D2M	Duct	Dual wavelength NDIR	Modbus RTU	NO
HSCD-D2ML	Duct	Dual wavelength NDIR	Modbus RTU	YES
HSCD-R2M	Room	Dual wavelength NDIR	Modbus RTU	NO
HSCD-R2ML	Room	Dual wavelength NDIR	Modbus RTU	YES

TECHNICAL SPECIFICATION

BASIC PARAMETERS	
PARAMETER	SPECIFICATION
CO2 Measurement principle	Single Wavelength NDIR: Single Wavelength non-dispersive infrared Dual Wavelength NDIR: Dual Wavelength non-dispersive infrared
MeasuringRange	0 to 9999 PPM
Sensor Accuracy* (@ 25 °C)	Single Wavelength NDIR: $\pm 40\text{PPM} \pm 3\%$ of measuring value Dual Wavelength NDIR: $\pm 30\text{PPM} \pm 3\%$ of measuring value
Repeatability	$\pm 20\text{ PPM} \pm 1\%$ of measuring value
Temperature Dependence	$\pm 2.5\text{ PPM} / \text{K}$ (Dual Wavelength NDIR)
Display Resolution	1 PPM
Responding Time (T63)	A. Sensing Module Responding Time: Single Wavelength NDIR: $\leq 30\text{S}$ Dual Wavelength NDIR: $\leq 20\text{S}$ B. Whole Unit Responding Time (Typically): Room Installation Type Single Wavelength NDIR: $\leq 75\text{S}$ Dual Wavelength NDIR: $\leq 45\text{S}$ Duct Installation type (airflowrate=4 m/s) Single Wavelength NDIR: $\leq 60\text{S}$ Dual Wavelength NDIR: $\leq 50\text{S}$
Warm-upTime	Single Wavelength NDIR: $\leq 60\text{ S}$ Dual Wavelength NDIR: $\leq 120\text{ S}$
Protection Standard (GB4208/IEC60529)	Duct Installation type: IP65/NEMA 4; IP20 for probe Room Installation Type: IP30
Automatic Self-Calibration Function	Available (On by default)
Calibration-free Service Life	10 Years (ACS function enabled)
Housing Materials	PC (UL94-V0)
Electromagnetic compatibility (Applications)	EN IEC 61326-1:2021 For use in residential, commerce, light industrial.

* 1. The carbon dioxide sensor is an optical sensor based on the infrared detection principle, so the accuracy of the sensor will deviate under continuous vibration.

2. The carbon dioxide sensor is a precision device. After handling, transportation and installation, the sensing accuracy may deviate. It will return to normal after being powered on for at least 7 days.

ELECTRICAL	
PARAMETER	SPECIFICATION
Power Supply	19.2~35VDC SELV24VAC $\pm 20\%$ 50/60Hz Class 2
Power Consumption	$\leq 3\text{VA}$
Analog Output Load	0-10V / 2-10V: Min5 k Ω 4-20mA: Max 500 Ω
Analog Output Resolution	0-10V / 2-10V: 10mV 4-20mA: 0.02mA
Analog Output Conversion Accuracy	0-10V / 2-10V: $\pm (20\text{mV} + 2\% \text{ Output Value})$ 4-20mA: $\pm (0.3\text{mA} + 2\% \text{ Output Value})$
Measurement Range with Guaranteed Accuracy	400 to 2000 PPM
Analog Output Range	0 to 2000 PPM
Number of connected Modbus RTU devices	A maximum of 64 devices can be connected to a single network segment

ENVIRONMENTAL		COMPLIANCE	
PARAMETER	SPECIFICATION	EU DIRECTIVE	STANDARDS
Operation Environment	Single Wavelength NDIR: 0 to 50 °C , 0 to 85 %RH (Non-condensing) Dual Wavelength NDIR: 0 to 50 °C , 0 to 95 %RH (Non-condensing)	2014/30/EU	EN 61326-1:2013 EN 61326-1:2021** **standards not yet harmonized by the European Commission
Storage Environment	Single Wavelength NDIR: 0 to 50 °C , 0 to 85 %RH (Non-condensing) Dual Wavelength NDIR: 0 to 50 °C , 0 to 95 %RH (Non-condensing)	2011/65/EU Amended by Directive (EU) 2015/863	EN IEC 63000:2018

FUNCTION AND SETTING

1. USER MANUAL FORCED RE-CALIBRATION (FRC) OPERATION

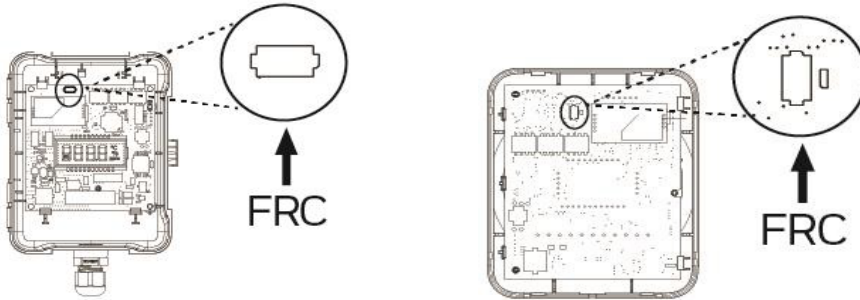

- Power on the Sensor product and place it in an outdoor atmospheric environment or a 400PPM carbon dioxide standard gas environment. The product needs to be covered to avoid sunlight and strong winds;
- Anti-static measures need to be taken, long press the button (FRC) on the PCB board for 4 seconds;
- For products without an LCD version, the LED will flash slowly, on for 2 seconds and off for 2 seconds (indicating that it is being calibrated); for products with an LCD version, “CALI” will be displayed as shown on the right.
- The stability of the ambient carbon dioxide concentration must be maintained during the calibration process. The calibration ends automatically after 11 minutes and the product returns to normal operation

Select analog output signal type: DIP No. S1-2 and No. S1-3			
DIPs Position			
Analog Output	4-20 mA (Default)	0-10V	2-10V

2 DIP SETTING A ANALOG OUTPUT TYPE

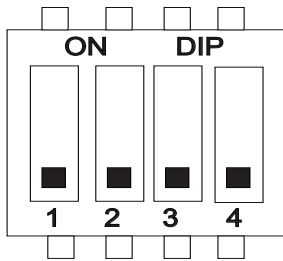

DIP No.	No. 1	No.2 & No.3
Function	Automatic Self-Calibration (ASC)	Analog output option

Set status of ASC: DIP NO.1		
DIP Position		
Automatic Self-Calibration (ASC)	4-20 mA (Default)	0-10V

Select analog output signal type: DIP No.2 and No.3	
DIPs Position	
Analog output	4-20mA (Default) 0-10V 2-10V

B MODBUS COMMUNICATION TYPE

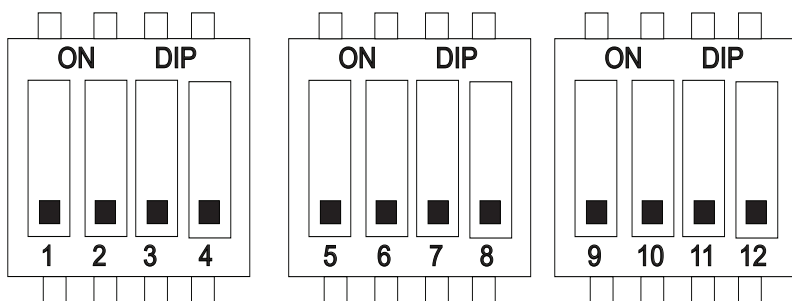

DIP No.	No. S1-1	No.2 & No.3	No.4 to No.10	No. 11	No. 12
Function	ASC	Modbus Baud Rate	Modbus Address	Reserved	RS485 Terminal Resistor

Set the mode of ASC: DIP NO.1	
DIP Position	
Automatic Self-Calibration (ASC)	Enable (Default) Disable

Set Modbus baud rate: DIP No.2 and No.3	
DIPs Position	
Baud rate	9600 (Default) 4800 19200 38400

Set Modbus address: DIP No.4 to No.10	
DIPs Position	
How to set Modbus address	<ol style="list-style-type: none"> DIPs No.4 to No.10 represent 1, 2, 4, 8, 16, 32 and 64 respectively. DIPs up to indicate selected number The sum of the selected numbers is the Modbus address code. As shown in the picture above: DIP No.8 and No.9 are selected, $16+32=48$, so the address code setting value is 48.

Set the mode of RS485 terminal resistor:DIPNo.12			
DIP Position			
Mode	<table border="1"> <tr> <td>Enable (Default)</td> <td>Disable</td> </tr> </table>	Enable (Default)	Disable
Enable (Default)	Disable		

MODBUS RTU PROTOCOL REGISTER ADDRESS INFORMATION

ID	ID FUNCTION	FUNCTION	QTY	READABLE (R) /WRITABLE (W)	DATA TYPE
0x01	Gas Concentration	Current gas concentration Unit: PPM	1	R	Short
0x02	Reserved		1	R	Short
0x03	Reserved		1	R	Short
0x04	ASC Status	ASC status, 0-Disable; 1-Enable	1	R	Short
0x05	FRC Target Value	FRCTarget Value Unit: PPM 400ppm)	1	R/W	Short
		Modify FRCValue by writing to this ID (Rang is 400 to 1000ppm)			
0x06	Reserved		1	R	Short
0x07	Reserved		1	R	Short
0x08	Reserved		1	R	Short
0x09	Error Code	0=Normal; 1=SensorError; 2=System Error	1	R	Short

FUNCTION CODE INFORMATION

CODE	FUNCTION	ERROR CODE	EXCEPTION CODE
0x03	Read holding register	0x83	01 or 02 or 03
0x06	Write single register	0x86	01 or 02 or 03
0x10	Write Multiple Registers	0x90	01 or 02 or 03

WIRING DIAGRAMS AND INSTRUCTIONS

0-10V/2-10/4-20MA ANALOG OUTPUT TYPE MODBUS COMMUNICATION TYPE

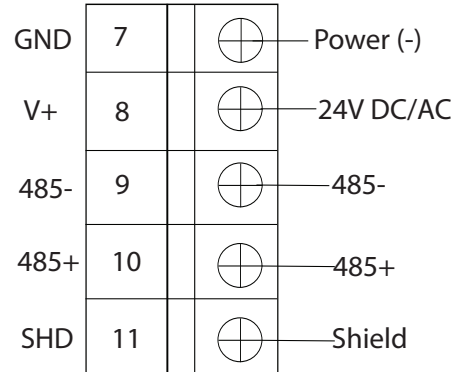
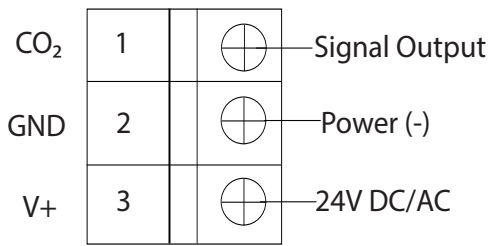

TIPS

- The terminals support AWG15 to AWG22 line types.
- The maximum lengths of different conductors are as follows:

LineType	AWG15	AWG16	AWG17	AWG18	AWG20	AWG22
Maxlength	300Meters	300Meters	150 Meters	150 Meters	150 Meters	50 Meters

- RS485 wiring requires a shielded cable with a maximum allowable length of 1200 meters.

DIMENSION (MM)

Room Installation Type

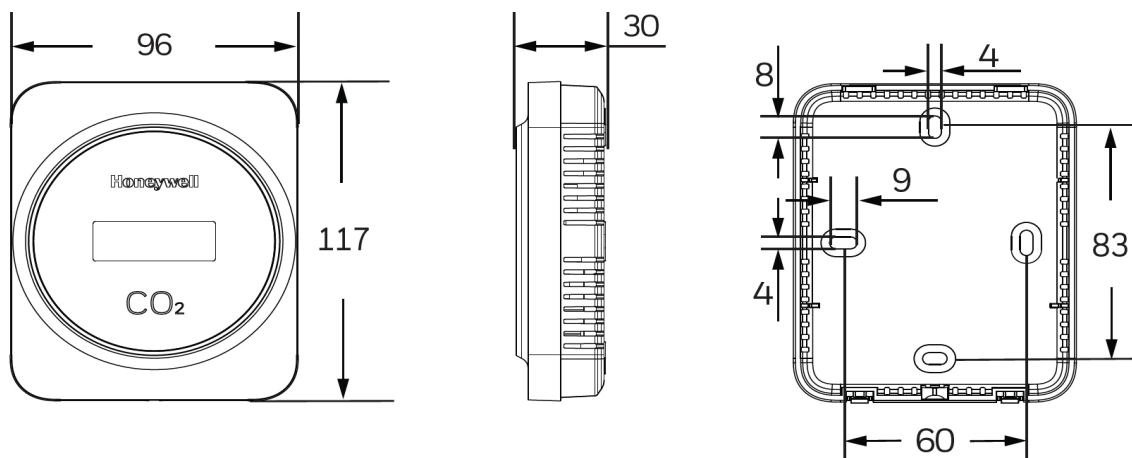

Duct Installation Type

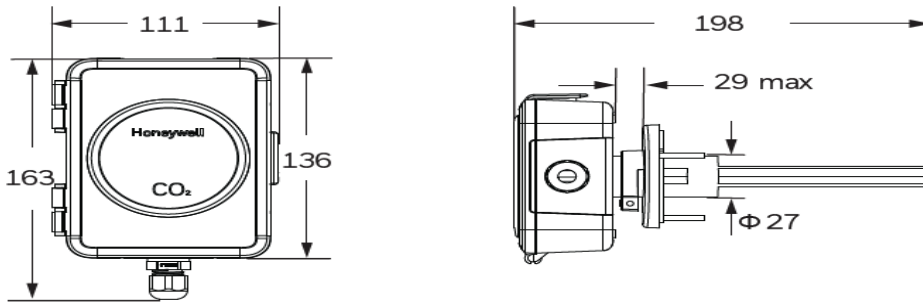

Fixed flange and conduit mounting hole

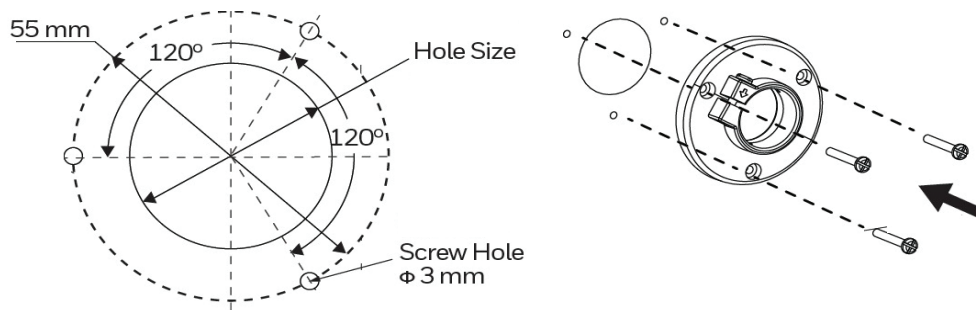

By using this Honeywell literature, you agree that Honeywell will have no liability for any damages arising out of your use or modification to, the literature. You will defend and indemnify Honeywell, its affiliates and subsidiaries, from and against any liability, cost, or damages, including attorneys' fees, arising out of, or resulting from, any modification to the literature by you.

Honeywell Products and Solutions Sàrl

Z.A. La Pièce 16 Rolle, 1180, Switzerland.

Honeywell GmbH

Hanns-Klemm-Straße 5

71034 Böblingen, Germany

<https://buildings.honeywell.com>

© 2025 Honeywell International Inc.
31-0797-01 | Rev 01-25